

JOB DESCRIPTION

JOB DETAILS	
Job Title	Specialist Therapist PT or OT
Reports to	The direct Band 7 line manager
Band	Band 6
Department/Directorate	Independent Living Centre

JOB PURPOSE

- Provide specialist assessment, diagnosis, treatment and advice to patients and their carers. The caseload will include a wide range of acute and chronic care cases, many having complex disabilities and needs. Some services will also include terminal care cases.
- Be part of:
The Independent Living Centre team working in a community setting
- All ensuring that therapy input is integrated into the patients' overall care plan.
- Work as an autonomous practitioner working without direct supervision and at times lone working.
- Provide supervision, training and support to junior staff and students.
- Work with managers to develop the service in line with patient need and trust wide developments, and to help provide an equitable service across the Trust.
- Some services are currently required to participate in on call and weekend working.

KEY RESULT AREAS/PRINCIPAL DUTIES AND RESPONSIBILITIES

The Specialist Therapist will be based in the community and /or hospital and/or clinic setting. The post holder will fulfil all tasks and work as part of a team. To meet the needs of the service, the post holder may be required to work in other areas as appropriate as directed by the line manager.

Caseload Management:

This post requires caseload management which will vary according to location and complexity. There will be a responsibility to provide advice to patients with potentially complex and specialist needs as well as carers and other disciplines

The post holder will pass on skills/knowledge to others within both formal and informal environments.

To have delegated responsibility for therapy staff, support staff and students.

Flexible Working

As services evolve changes to working patterns maybe required.

To meet the needs of the service, the post holder may be required to work in other areas as appropriate as directed by the line manager.

Budget

To be responsible for the use of resources in the most efficient and effective way.

To authorise spending on equipment from Community Equipment Store to a value of £1,000 [2008] following authorisation training.

On-call and week-end working responsibilities

On-call and weekend working rotas are in addition to normal working hours.

There is also a requirement to work on bank holidays recompensed in line with Agenda for Change for orthopaedic, neuro-rehabilitation and in-patient rotas and the Trust's Single on-call remuneration framework for the On-call respiratory rota.

Physiotherapists will be required to work autonomously on the out-of-hours respiratory on-call rota Monday to Sunday or weekend working on the orthopaedic, respiratory or inpatient rotas on Saturday and Sunday. This may include being a resource or "buddy" for other therapists working on rotas. All qualified physiotherapy staff are expected to participate in the on-call or weekend working rotas and take fair share of bank holiday working.

On call expectations:

- Band 6 physiotherapists working outside of acute or community respiratory specialisms will be expected to participate in the respiratory on-call rota for a minimum of 3 years from moving to a non-respiratory post (subject to service requirements).
- Band 6 Physiotherapists working in respiratory specialisms in acute and community services will be expected to continue on the on-call respiratory rota.
- Physiotherapy staff working on the on-call rota will be expected to be able to attend a call-out within 30 minutes of the call. If living more than 30 minutes from the trust, the physiotherapist can arrange an on-call room on site
- Occupational Therapists will be required to work autonomously on the orthopaedic or inpatient rotas on Saturday and Sunday, to be discussed with the line manager and Service Lead for Acute Inpatient Therapy).

KEY WORKING RELATIONSHIPS

Areas of Responsibility:

The post holder will be responsible for providing specialist assessments and expert equipment advice for Devon residents who visit or contact the Independent Living Centre in order to:

- assess the person's functional needs including people with chronic and complex needs.
- enable people with complex needs to maximise their physical, emotional, cognitive, social function.
- anticipate and prevent the effects of health conditions through education and therapeutic intervention in a functional context.
- provide practical advice and support for families and carers of people with disabilities.
- identify solutions and appropriate equipment for activities of daily living.

The post-holder will pro-actively carry out research into equipment and participate in the maintenance of up to date information.

The post-holder will ensure that the ILC maintains and develops access to specialist equipment for assessment and demonstration by liaising with equipment manufacturers and retailers.

The post-holder will be instrumental in making clinical judgements regarding the equipment available for access through statutory bodies.

The post holder will use equipment knowledge and research to advise and support colleagues in NHS and DCC to facilitate provision of timely and cost effective specialist equipment

The post holder will be involved with developing the service in response to county equipment policy and identified equipment prescriber training needs. The post holder will be instrumental in planning, co ordinating and presenting equipment updates and training to multidisciplinary employees from Adult Health and Social Care.

The post holder will represent the ILC team at peer group meetings and management meetings as required as well as representing the ILC at events for clients, formal and informal carers, and the general public throughout Devon

The post holder will take a lead on behalf of the ILC for specific projects

No. of Staff reporting to this role: 1

The post holder is required to deal effectively with staff of all levels throughout the Trust as and when they encounter on a day to day basis (Delete/amend as necessary)

In addition the post holder will deal with the wider healthcare community, external organisations and the public. (Delete/amend as necessary)

This will include verbal, written and electronic media.

Of particular importance are working relationships with:

Internal to the Trust	External to the Trust
<ul style="list-style-type: none">• Clerical Staff• Service Lead• Complex Care teams• Trust staff at all levels• Nursing staff / specialist nurses	<ul style="list-style-type: none">• Community Equipment Provider• CES Operational and improvement manager• GPs and other practice staff -as required• Other specialist services -as required• Patients, relatives and carers• Social Services• Voluntary agencies -as required

ORGANISATIONAL CHART

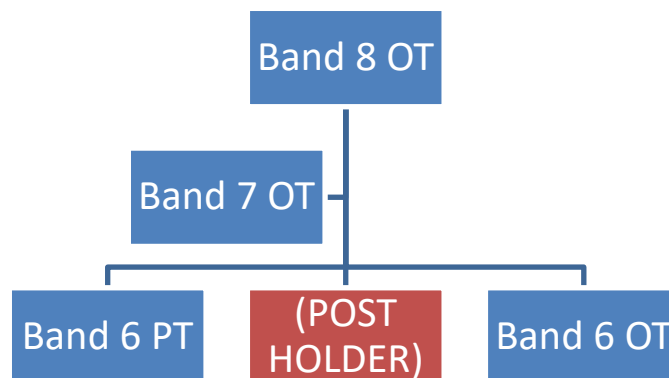

FREEDOM TO ACT

- Adhere to HCPC professional standards of practice.
- Be professionally accountable for all aspects of your own work, within the context of an autonomous practitioner.
- Undertake specific projects as required.

COMMUNICATION/RELATIONSHIP SKILLS

- To use and develop effective communication and motivational skills with patients and carers to gain their cooperation for treatment and maximise rehabilitation potential and to ensure understanding of more complex conditions.
- Ensure effective communication takes place at all times, taking a team approach to patient care and service needs.
- Attend multidisciplinary meetings and case conferences to ensure that there is an integrated approach that benefits patient's overall care and discharge plans.
- Be prepared to give talks/demonstrations regarding your work to colleagues and others.
- Write comprehensive reports regarding patient assessment, treatment outcomes and recommendations to GPs, consultants, other health and social care colleagues and other members of the multidisciplinary team.
- Liaise closely with all members of the health care team and other agencies in all matters regarding patients care, discharge and future care management.
- Convene and participate in multidisciplinary and cross agency case conferences and visits as appropriate.
- Communicate complex and sensitive information e.g. prognosis.
- Work with patients referred with complex communication and cognitive problems e.g. following a stroke and other neurological conditions.
- Obtain patient consent and work within a legal framework with patients who lack capacity to consent to treatment.

ANALYTICAL/JUDGEMENTAL SKILLS

- Undertake a comprehensive, holistic clinical assessment of patients presenting with complex multi-factorial problems using specialist analytical skills and clinical reasoning. At times the patients will have highly complex needs.
- Work in collaboration with other teams in order to support a consistent and equitable service across the Trust.
- Contribute to the development of integrated locality teams.
- Propose changes to improve practice in line with local and national guidelines.
- Undertake risk assessment, using specialist clinical judgement and provide accurate feedback to the team as necessary e.g. in relation to lone working.

- Apply specialist clinical reasoning skills after assessment to decide appropriate treatment plan and approach.
- Read and interpret a range of patient medical, medication, social history and social care plans.

PLANNING/ORGANISATIONAL SKILLS

- Plan patients care, managing an individual caseload of complex patients effectively and efficiently.
- Exercise good personal time management, punctuality and consistent reliable attendance.
- Co-ordinate patient appointments.
- Organise and carry out therapy home assessment, to include liaison with patients, carers and transport services.
- Organise own day to day activity and that of support staff and junior staff, delegating activities and providing specialist advice as appropriate.
- Take part and lead group sessions e.g. falls groups, VISTA.
- Thinking ahead and planning delivery of services over the longer term e.g. clinics / classes over a 12-month period.

PATIENT/CLIENT CARE

- Manage own complex caseload and treatment programmes to a high standard expected of an experienced clinician without day to day clinical supervision. Support is available through the clinical supervision programme and from more specialist or skilled staff in a particular area.
- Prioritise, assess and treat patients referred, taking an evidence-based and reflective practice approach using community rehabilitation skills and specialist knowledge, including a wide range of modalities and skills in order to maximise patient/user independence.
- Identify specific problems and develop goals and specialist treatment plans in partnership with the patient and others to enable treatment plans to be carried out effectively for the discharge of patients.
- Evaluate patient/user progress, and modify treatment/input if required.
- Provide specialist level teaching and guidance to both patients and carers as required.
- Maintain accurate and timely patient records and reports using agreed standard formats.
- Facilitate the discharge process as appropriate.
- Be professionally accountable for all aspects of your own work, within the context of an autonomous practitioner.
- The post holder is expected to comply with Trust infection control policies & conduct him/herself at all time in a manner as to minimise the risk of health care associated infections.

POLICY/SERVICE DEVELOPMENT

- Keep abreast of professional and related NHS/Social Services developments in liaison with Professional/ Service Lead colleagues.
- Identify opportunities to improve the service, taking account of resources available, discussing your ideas with colleagues and Therapy Lead/ Manager.
- Participate in the operational planning and implementation of policy and service development within the team, leading on delegated priorities.
- Be aware of and follow the Health and Safety at Work Act and local/national guidelines, reporting any incidents using the correct procedures (DATIX).
- Report any accidents/ untoward incidents/ near misses to self, patients or carers to the manager in accordance with Trust policy.
- Be aware of and follow Trust policies and procedures and Health and Care Professions Council codes of professional practice.

FINANCIAL/PHYSICAL RESOURCES

- Assess for, prescribe and order equipment following fair access to care and retail model criteria
- Be responsible for safe and competent use of all equipment and patient appliances and ensure junior/clinical support workers obtain competency prior to use.
- Ensure equipment has appropriate checks made. Report any equipment defects, taking action to ensure any such equipment is withdrawn from service.
- Demonstrate and instruct on the use of equipment to ensure safety.
- Understand and apply the eligibility criteria for services.

- Support the team leader and therapy manager in the efficient and effective use of resources.

HUMAN RESOURCES

- Supervise junior staff, students and other members of staff where necessary.
- Participate in clinical supervision as supervisor and supervisee.
- Participate in staff appraisal as appraiser and appraisee, identifying own and others areas for development in line with Knowledge and Skills Framework Competencies.
- Participate in and where necessary lead and teach at training sessions for staff and other agencies.
- Be prepared to share areas of knowledge and experience both formally and informally.
- Ensure that Health and Care Professions Council registration is maintained through continuing professional development activity and is evidenced to line manager.
- Assist in the recruitment of relevant grades of staff as appropriate.
- Work with the Manager/s to ensure clinical cover across the cluster/s is maintained especially at times of service pressure.

INFORMATION RESOURCES

- Contribute to the collection of statistical data, in order to monitor and develop team activity, using electronic and paper methods.
- Contribute to methods to most effectively manage caseload pressures.
- Maintain accurate and timely patient records using agreed standard formats.

RESEARCH AND DEVELOPMENT

- Maintain an up to date knowledge of all areas of clinical practice using a variety of CPD methods and to maintain a CPD portfolio.
- Participate in clinical governance activities e.g. audit, research, service reviews, taking a lead if delegated to do so.

PHYSICAL SKILLS

- Assess, prescribe and demonstrate the safe use of equipment, including wheelchairs in a variety of settings including the patient's home.
- Basic computer skills to maintain patient records, record activity, e mail and order equipment etc.
- Therapeutic handling of patients (e.g. positioning, stair practice) demonstrating dexterity, co-ordination and palpatory skills often with the need for prolonged physical effort. This will include patients with complex and highly specialist needs.

PHYSICAL EFFORT

- Manually handle equipment (wheelchairs, health care equipment) and furniture frequently, following ergonomic risk assessment as per statutory training and service risk assessment.
- Treatment may necessitate working in restricted positions or limited space.
- Driving to meet the requirements of the post.
- Manual therapeutic handling of patients e.g. during stroke therapy.
- Daily moving and handling of patients in relation to assessment, treatment and rehabilitation
- Work in the community where appropriate equipment is often not available. (e.g. moving and handling equipment).

MENTAL EFFORT

- Manage competing demands of providing services on a daily basis.
- Read, decipher and interpret patient information.
- Work in an unpredictable work pattern.
- Frequent mental effort in assessment and treatment programmes.
- Identify strategies to motivate patients to comply with their treatment plan.

EMOTIONAL EFFORT

- Work with patients who may have a poor/life limiting prognosis.
- Work with patients in the aftermath of bad news.
- Work with patients with mental health problems and occasional challenging behaviour.
- At times talk to relatives following a death.

WORKING CONDITIONS

- Work in a variety of settings according to patient needs including patients own home which can often involve hot/cold temperatures, cluttered, noisy and unhygienic environments.
- Work with patients with a wide range of conditions including contact with body fluids.

OTHER RESPONSIBILITIES

Take part in regular performance appraisal.

Undertake any training required in order to maintain competency including mandatory training, e.g. Manual Handling

Contribute to and work within a safe working environment

You are expected to comply with Trust Infection Control Policies and conduct him/herself at all times in such a manner as to minimise the risk of healthcare associated infection

As an employee of the Trust, it is a contractual duty that you abide by any relevant code of professional conduct and/or practice applicable to you. A breach of this requirement may result in action being taken against you (in accordance with the Trust's disciplinary policy) up to and including dismissal.

You must also take responsibility for your workplace health and wellbeing:

- When required, gain support from Occupational Health, Human Resources or other sources.
- Familiarise yourself with the health and wellbeing support available from policies and/or Occupational Health.
- Follow the Trust's health and wellbeing vision of healthy body, healthy mind, healthy you.
- Undertake a Display Screen Equipment assessment (DES) if appropriate to role.

APPLICABLE TO MANAGERS ONLY

Leading the team effectively and supporting their wellbeing by:

- Championing health and wellbeing.
- Encouraging and support staff engagement in delivery of the service.
- Encouraging staff to comment on development and delivery of the service.
- Ensuring during 1:1's / supervision with employees you always check how they are.

DISCLOSURE AND BARRING SERVICE CHECKS

This post has been identified as involving access to vulnerable adults and/or children and in line with Trust policy successful applicants will be required to undertake a Disclosure & Barring Service Disclosure Check.

GENERAL

This is a description of the job as it is now. We periodically examine employees' job descriptions and update them to ensure that they reflect the job as it is then being performed, or to incorporate any changes being proposed. This procedure is conducted by the manager in consultation with the jobholder. You will, therefore, be expected to participate fully in such discussions. We aim to reach agreement on reasonable changes, but if agreement is not possible, we reserve the right to insist on changes to your job description after consultation with you.

Everyone within the Trust has a responsibility for, and is committed to, safeguarding and promoting the welfare of vulnerable adults, children and young people and for ensuring that they are protected from harm, ensuring that the Trusts Child Protection and Safeguarding Adult policies and procedures are promoted and adhered to by all members of staff.

PERSON SPECIFICATION

Job Title	Specialist Therapist
------------------	----------------------

Requirements	Essential	Desirable
QUALIFICATION/ SPECIAL TRAINING		
Degree or Graduate Diploma in therapy	E	
HCPC registration	E	
Additional post-graduate training relevant to the post eg moving & handling, clinical skills training.	E	
KNOWLEDGE/SKILLS		
Evidence of continuing professional development	E	
Knowledge of relevant NSF's, appropriate national guidance and other relevant initiatives	E	D
Evidence of participating in Clinical Audit		
Multi-disciplinary team working across health, social and voluntary sectors	E	
Proven ability of complex case management	E	
Excellent communication skills	E	
Core IT skills	E	
EXPERIENCE		
Post-graduate experience in a range of settings to evidence sound core skills and demonstrate evidence working with a variety of different conditions.	E	
Evidence clinical experience and competence in a relative clinical setting for the post	E	
Evidence of supervisory experience	E	
PERSONAL ATTRIBUTES		
Able to work as a team member	E	
Good time management	E	
Good organisational skills	E	
Self-awareness of own levels of competence	E	
OTHER REQUIREMENTS		
The post holder must demonstrate a positive commitment to uphold diversity and equality policies approved by the Trust.	E	
Ability to travel to other locations as required	E	

WORKING CONDITIONS/HAZARDS		FREQUENCY (Rare/ Occasional/ Moderate/ Frequent)			
		R	O	M	F
Hazards/ Risks requiring Immunisation Screening					
Laboratory specimens	N				
Contact with patients	Y				X
Exposure Prone Procedures	N				
Blood/body fluids	Y				X
Laboratory specimens	N				
Hazard/Risks requiring Respiratory Health Surveillance					
Solvents (e.g. toluene, xylene, white spirit, acetone, formaldehyde and ethyl acetate)	N				
Respiratory sensitisers (e.g isocyanates)	N				
Chlorine based cleaning solutions (e.g. Chlorclean, Actichlor, Tristel)	N				
Animals	N				
Cytotoxic drugs	N				
Risks requiring Other Health Surveillance					
Radiation (>6mSv)	N				
Laser (Class 3R, 3B, 4)	N				
Dusty environment (>4mg/m3)	N				
Noise (over 80dBA)	N				
Hand held vibration tools (=>2.5 m/s2)	N				
Other General Hazards/ Risks					
VDU use (> 1 hour daily)	Y				X
Heavy manual handling (>10kg)	Y			X	
Driving	N				
Food handling	N				
Night working	N				
Electrical work	N				
Physical Effort	Y				X
Mental Effort	Y				X
Emotional Effort	Y				X
Working in isolation	Y		X		
Challenging behaviour	Y		X		